

### FEATURES

The MultiSensor module MSM01 has built in **temperature and humidity sensors**, with 2 external inputs for **water leakage detection** cables as well as 4 general purpose inputs for use with the Cytech Environmental Monitoring System CM9001-EMS

<http://www.cytech.biz/brochure/ems.html>

CM9001-EMS is an advanced Environmental Monitoring System which monitors equipment failure as well as sensor data so that alarms can be triggered if programmed setpoints are exceeded in unattended facilities like **data centres, server rooms, wine chillers, telecom base stations, and pharmaceutical freezers**.

CM9001-EMS is a modular system which allows easy expansion of functions, Input/Outputs, and external interfaces like Modbus, KNX and C-Bus, or RS232 and RS485 interfaces.

MSM01 can also be used to supply temperature and humidity data to Modbus, KNX and C-Bus and other systems.

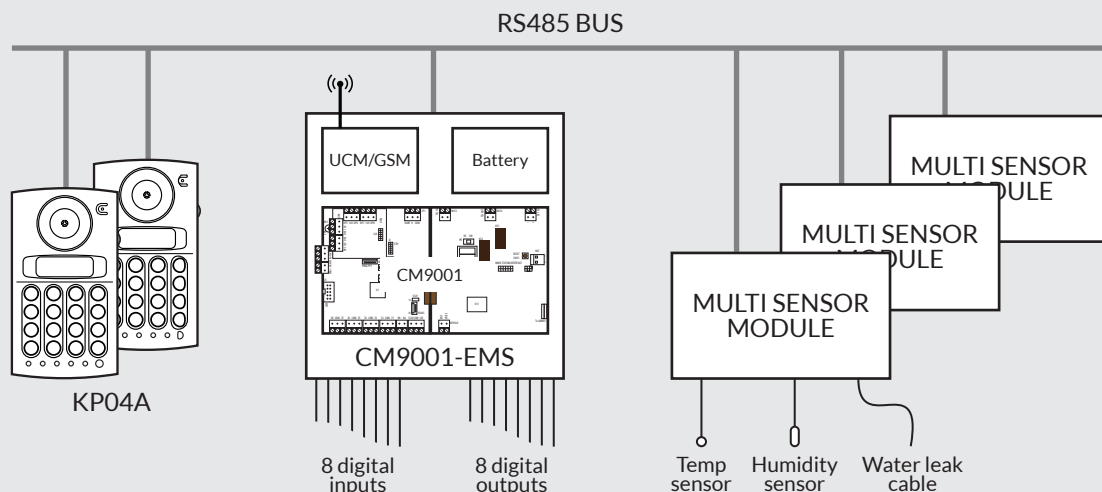

Schematic of CM9001-EMS with MSM01 Modules

Up to 15 MSM01 can be connected to a CM9001-EMS system

## APPLICATION MARKETS

1. Data centres
2. Commercial/industrial refrigeration systems
3. Telecom towers
4. Wine chillers
5. Hotel rooms and offices
6. Any unattended facilities

## SENSOR SPECIFICATION

## SENSORS

**Temperature**

Temperature range: 0 to 80 deg C

Accuracy: +/- 1 deg C (at 25% 60 % RH)

**Humidity**

Humidity Range: 0-100 % RH

Accuracy: +/- 3 % RH (at 25% 60 % RH)

**Water Leak**

2 inputs for Water Leak Sensor/Cable WA01-0043 with End-of-Line Resistor for detection of cable break. Triggers Zone Trouble alarm

## DIGITAL INPUTS

4 inputs individually configurable as Digital (Open/Close contacts) or Analog 0-10V

## ENCLOSURE

145 x 90 x 40mm ABS Flame Retardant (V-O grade) plastic enclosure. Wall mount or DIN rail mounted

## POWER SUPPLY

12V DC 50mA (from CM9001 or UCM/Logic Controller)

## PROGRAMMING

By the FREE Configurator Software

<http://www.cytech.biz/comfigurator.html>

## CONTROLLERS

MSM01 can be connected to the following controllers;

- CM9001-EMS Environmental Monitoring System
- CM9001-ULT Comfort integrated Alarm/Automation System
- UCM/Logic Logic Controller with no I/O
- LGX01 Logic controller with 8 inputs, 8 outputs